

A Govt. of India Recognised Export House

📍 Hara Industrial Estate Kanganwal, Sua Road Industrial Area- C, Ludhiana

☎ +91-161-5041164 📞 +91-98035-88111

✉ sid@xceleexports.com, sales@xceleexports.com

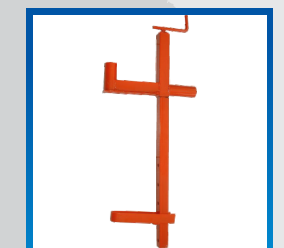
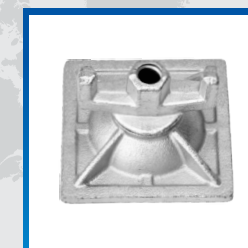
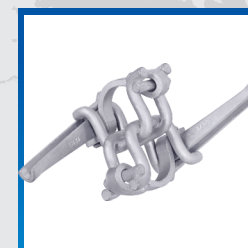

A Govt. of India Recognised Export House

**SCAFFOLDING | FORMWORK | SHORING**





## About us

Xcel exports is a Manufacturer and Exporter of scaffolding and accessories. In the year of 2010, Xcel group became multinational by establishing an outsourcing network office at china.

### INFRASTRUCTURE

We have set up the ultramodern infrastructure in our firm that enables us in producing the optimum quality products in industry. Our hi-tech production facilitates us in gaining the utmost client satisfaction through qualitative range of products. Our infrastructure is segmented into various units to make the tasks and operations in easier and smooth manner.

### OUR QUALITY ASSURANCE

Quality is the way of life at XCEL. From the steady hands of the surgeon to the nimble fingers of the diamond cutter, some things are best left to experts. XCEL Group has a pool of machinery & quality checking tools, an in house fully equipped standard room and a team of proficient engineers & workers who possess skilled workmanship and are expertise in ensuring high quality standards. Our first priority is to maintain the quality and reliability of the products; therefore we follow international quality standards and norms in manufacturing them. We have a team of highly skilled and experienced quality controllers, who keep an eye on each stage of the production processes, thereby ensuring their flawlessness and optimum finishing.

### OUR TEAM

Our firm is equipped with the immensely skilled and adroit professionals, who are well versed in their respective domains and posses rich industry experience. We conduct different development programs and sessions in order to increase the knowledge and skills of the employees. Our staff members work with mutual understanding for their easier and smooth operation.

### WHY US?

We have gained huge appreciation and demand across the globe by offering qualitative range of products. We offer our range in diverse specifications and at most competitive rates that suit the budgetary limits of the clients. Besides this, our fair dealing, ethical business practices and easy payment modes make us the first choice of the clients.

**WE HAVE VERTICAL DIVISIONS IN OUR COMPANY. OPERATING FROM INDIA & CHINA.**

### OUR MISSION

The mission of our group is to provide our invaluable customers with the best quality products, assuring them our co-operation every moment and in the process, satisfying their needs and expectations, there by achieving the most alluring level in service, customer satisfaction.



**OUR CAPABILITIES** ..... **01-02**



**RING LOCK SYSTEM** ..... **03**



**CUP LOCK SYSTEM** ..... **04**

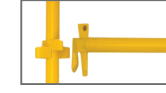

**KWIKSTAGE SYSTEM** ..... **05**

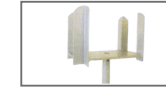

**PROPS & ACCESSORIES** ..... **06**



**SHORING TOWER** ..... **07**

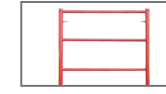

**FRAME SYSTEM** ..... **08**



**SCAFFOLDING ACCESSORIES** ..... **09**

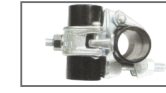

**FORGED COUPLERS** ..... **10**

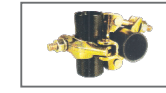

**PRESSED COUPLERS** ..... **11**



**FORMWORK PANEL & ACCESSORIES** ..... **12**

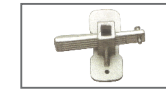

**FORMWORK ACCESSORIES** ..... **13-14**



**ADJUSTABLE JACKS & U-HEADS** ..... **15**

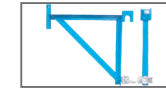

**SAFETY GUARD RAILS & BARRIERS** ..... **16**



**ALUMINIUM PRODUCTS** ..... **17**

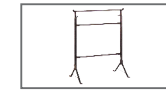

**OTHER PRODUCTS** ..... **18**



**OTHER PRODUCTS AND CASTER WHEEL** ..... **19**



**OTHER SAFETY PRODUCTS** ..... **20**



**ENGG.& DEVELOPMENT**

Xcel Exports offers end-to-end solutions to its global customers, based on its extensive technology, product design & product development. The use of latest software Like Solid Work & Auto Cad Inventor accelerates response time in developing new parts.

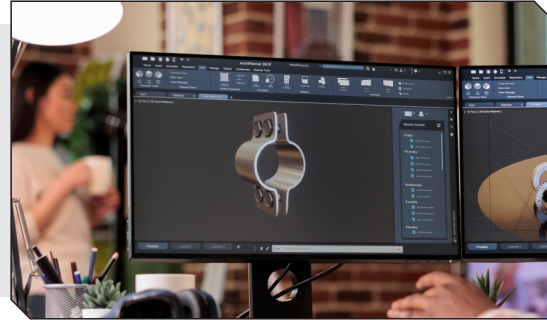
**QUALITY ASSURANCE LAB**

Quality forms the bottom line for all our operations. Our QA Department has in house labs for NDT & DT which includes UTM, Spectrometer, Hardness Testing, Impact Testing at extreme low temperature, CMM, Image Analyser & Salt Spray Chamber. Our Inspections and Testing facilities include - Metallurgical, Physical, and Chemical & Standard Room.

**TOOL & DIE MANUFACTURING**

Eastman complete in-house setup for tool manufacturing enables us to spontaneously answer new product development, engineering changes during project running & cater small and large production volumes effectively.

**FABRICATION**

Fabrication is dedicated to construction industry products, are equipped with laser cutting, Robot welding, Brake press and 25 welding stations. Our welding is certified from SLV Mannheim, Germany for En 1090 and ISO 3830. Total fabrication capacities is 2200 tons per month.

**CASTING**

Modernized plant for SG and CI sand casting. Having Automatic sand plant and high pressure moulding line (SINTO).

**FORGINGS**

Capable of forging wide range of parts starting from 0.5 to 50 kg. All our forging machines are equipped with induction billet heater for better material flow and surface finish of the parts.

**MACHINING**

In our manufacturing unit we have set up of CNC and conventional machines for converting raw casting and forging to ready to fit parts.

**HEAT TREATMENT**

State of art PLC controlled heat treatment plant ensures consistent metallurgical properties through Normalizing, Hardening, Tempering, ISO Thermal Annealing, Case Carburizing and Quenching.

**FACILITY**

We have In-House Hot Dip galvanizing, Powder Coating & Paint Facility. Hot Dip galvanizing Zinc bath is 4m long, Powder Coating is done on a conveyerized semi-automatic line. Paint plant has 7 tank phosphating process.



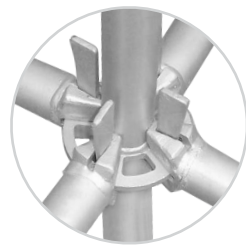

HORIZONTAL	
Size (Mtr)	Weight (Kg)
0.88	3.99
1.065	4.57
1.15	4.84
1.57	6.43
2.13	8.38
3.05	11.56



DIAGONAL	
Size (Mtr)	Weight (Kg)
1.065X2.00	7.81
1.52X2.00	8.44
1.57X2.00	8.51
2.13X2.00	9.50
3.05X2.00	11.45

VERTICAL	
Size (Mtr) (with bolted Spigot)	Weight (Kg)
3.00	14.90
2.00	10.26
1.50	8.06
1.00	5.75
0.50	3.45

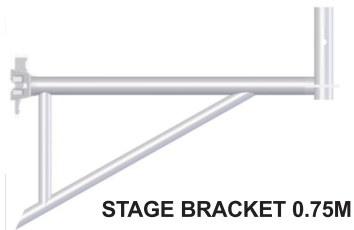

REINFORCED HORIZONTAL	
Size (Mtr)	Weight (Kg)
1.57	10.69
2.13	14.25
2.43	16.60
3.05	21.10

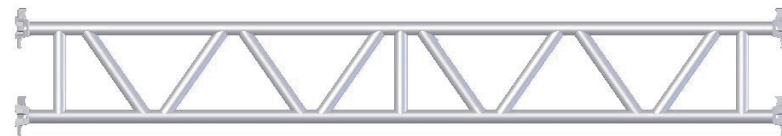

BRIDGING LEDGER	
Size (Mtr)	Weight (Kg)
4.26	46.60
6.39	68.45
8.52	92.76

### ACCESSORIES

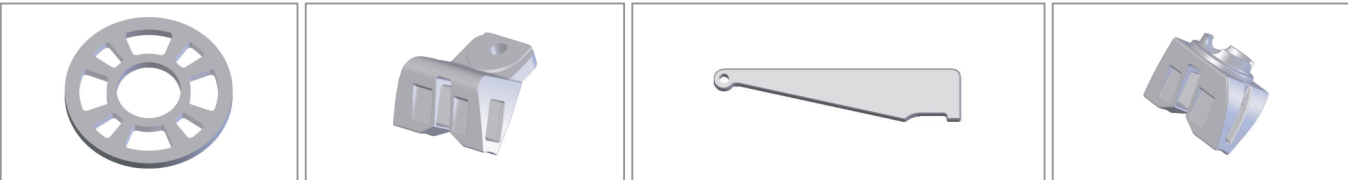

Frame Ring/Rosette Ring

Brace End

Ringlock Wedge

Ledger End

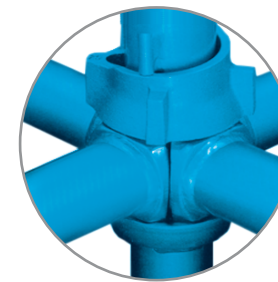

VERTICAL / STANDARD	
Size (Mtr)	Weight (Kg)
1.0	4.96
1.3	5.92
1.5	7.43
1.8	8.34
2.0	9.91
2.5	12.38
3.0	14.82

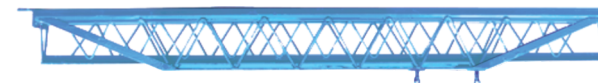

ADJUSTABLE BEAM SPAN				
Combination	Minimum	Maximum	Name of Member	Length
ESO + ESI	1900	2650	Extra Short Outer	1500 mm
SO + ESI	2650	3650	Short Outer	2500 mm
SO + SI	2650	3650	Long Outer	3000 mm
SO + LI	3150	4400	Extra Short Inner	1500 mm
LO + SI	3150	4900	Short Inner	2500 mm
LO + SI	3150	5400	Long Inner	3000 mm



DECKING BEAM	
Size (Mtr)	Weight (Kg)
1.2	11.13
1.8	18.89
2.5	25.49

AVAILABLE FINISH:- HDG | OVEN BAKED PAINTED | POWDER COATED

### ACCESSORIES



Bottom Cup

Ledger Blade

Swivel Blade

Top Cup - Casted / Forged

Spigot - Square / Round



HORIZONTAL / LEDGER	
Size (Mtr)	Weight (Kg)
0.60	2.36
0.90	3.39
1.00	3.74
1.20	4.43
1.30	4.77
1.60	5.81
1.80	6.50
2.50	8.91



INTERMEDIATE TRANSOM	
Size (Mtr)	Weight (Kg)
0.565	5.60
0.795	6.42
1.200	7.85
1.300	8.22
1.800	10.0
2.500	12.5



INSIDE BOARD TRANSOM	
Size (Mtr)	Weight (Kg)
1.621	7.50



**FACE BRACE  
EICL-01F**



INFILL BEAM			
Size (Mtr)	Weight (Kg)	Size (Mtr)	Weight (Kg)
0.9	5.4	1.8	10.80
1.0	6.0	2.5	15.0
1.2	7.3		

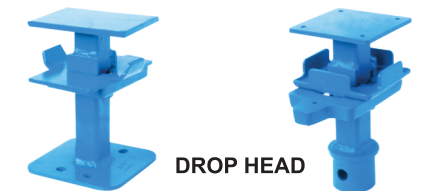





LEDGER	
Size(mtr.)	Wt. (kg.)
1.2	5.55
1.8	6.95
2.4	8.85



TRANSOM	
Size(mtr.)	Wt. (kg.)
0.8	5.90
1.2	9.70
1.8	13.10



FACE BRACE (EIKS-01D)	
Size(mtr.)	Wt. (kg.)
2.74	10.90
3.54	13.10



TIE BAR	
Size(mtr.)	Wt. (kg.)
1.245	3.52
1.803	5.20
2.413	7.00



STAGE BRACKET		
Description	Size(mtr.)	Wt. (kg.)
1 Board	0.243	2.34
2 Board	0.510	5.82
3 Board	0.738	9.54

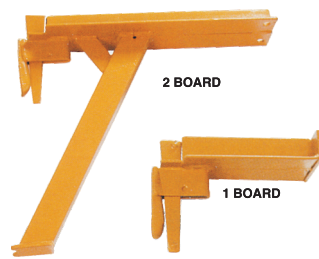

VERTICAL/STANDARD WITH SPIGOT	
Size(mtr.)	Wt. (kg.)
1.0	6.20
2.0	11.70
2.5	14.40
3.0	17.20



### ACCESSORIES



AVAILABLE FINISH:- OVEN BAKED PAINTED | POWDER COATED

HEAVY DUTY PROPS		
Item Code	Closed Ht./Open Ht. (m)	Weight (kg.)
7021	1.07/1.82	11.00
7022	1.75/3.12	16.70
7023	1.98/3.35	18.40
7024	2.59/3.95	20.20
7025	3.20/4.87	24.20

LIGHT DUTY PROPS		
Item Code	Closed Ht./Open Ht. (Mtr)	Weight (Kg)
7031	0.25/0.50	3.30
7032	0.50/0.80	4.10
7033	0.70/1.30	5.00
7034	1.00/1.80	5.90
7035	1.60/2.90	9.70
7036	2.00/3.60	10.70
7037	2.50/4.50	11.70
7038	3.00/5.00	13.40

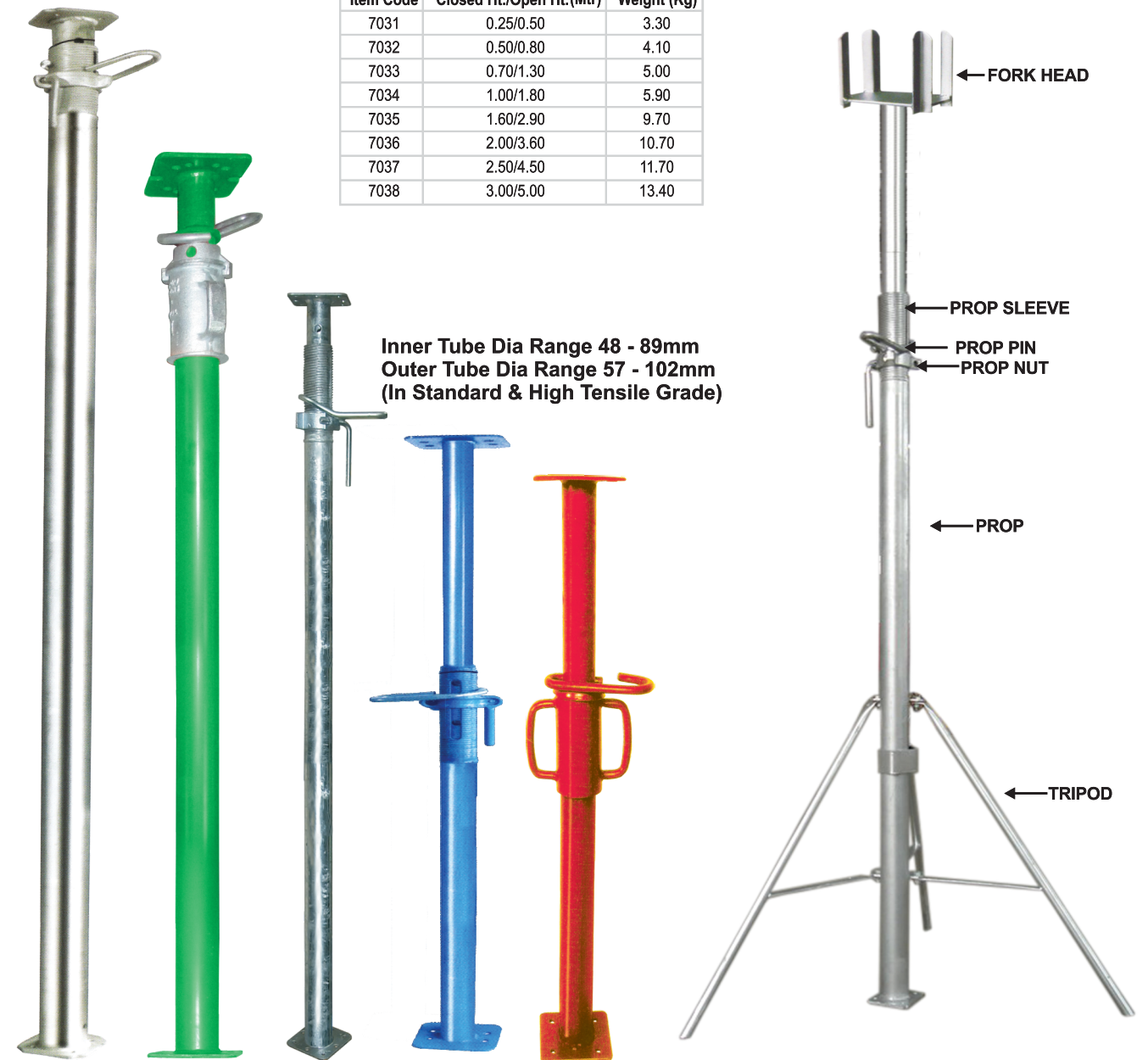

### ACCESSORIES

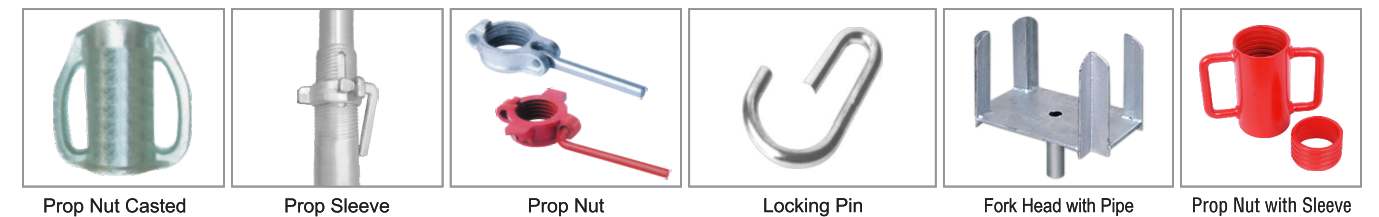

AVAILABLE FINISH:- HDG | OVEN BAKED PAINTED | POWDER COATED



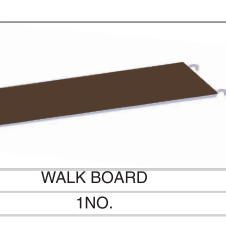
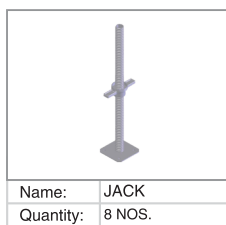
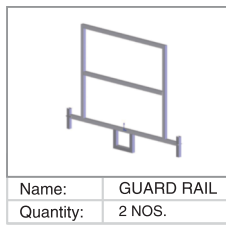
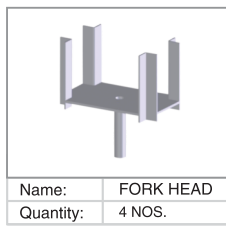
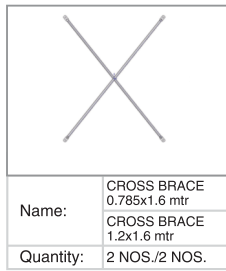
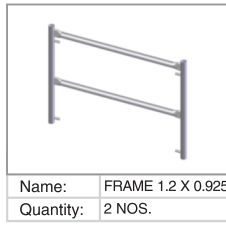
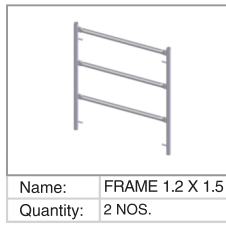
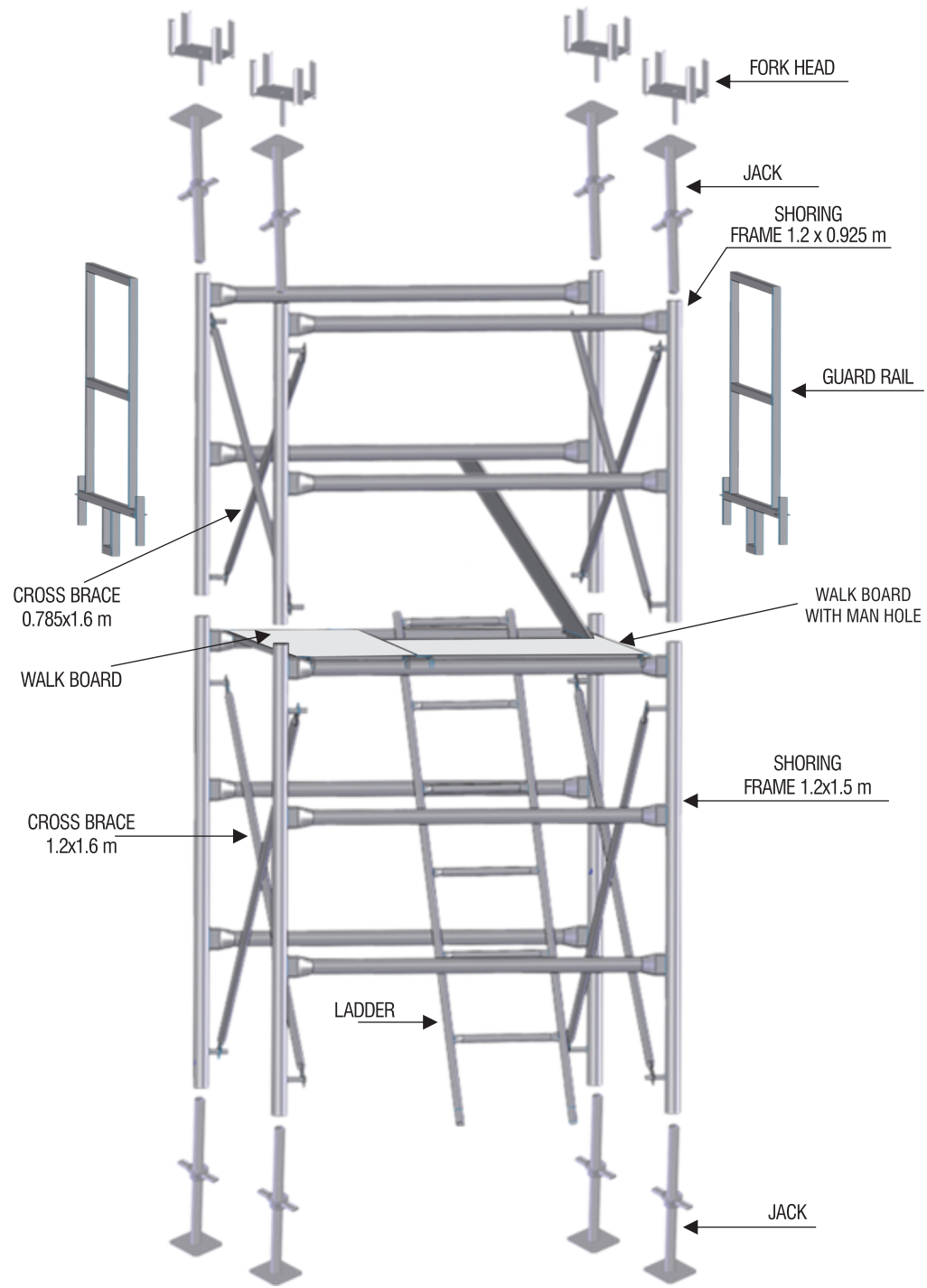

AVAILABLE FINISH:- HDG | OVEN BAKED PAINTED | POWDER COATED

Name	LADDER
Quantity	1 NO.

Name	WALK BOARD WITH MAN HOLE
Quantity	1 NO.

Name	WALK BOARD
Quantity	1NO.

### SCAFFOLDING WALK THRU FRAMES (S-STYLE)

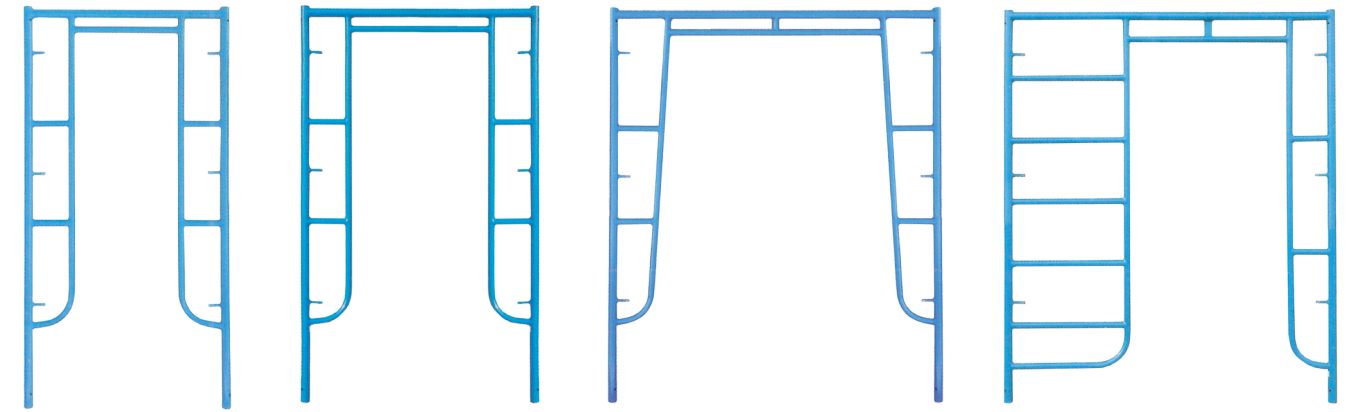

3'X6'4" WALK THRU FRAME

42"X6'4" WALK THRU FRAME

5'X6'4" WALK THRU FRAME

5'X6'4" LADDER & WALK THRU FRAME

### SCAFFOLDING MASON FRAMES (S-STYLE)

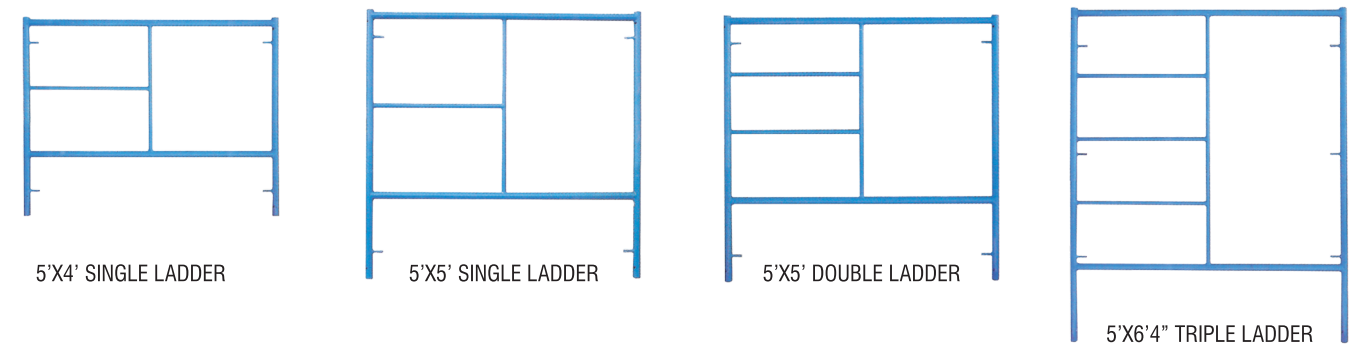

5'X4' SINGLE LADDER

5'X5' SINGLE LADDER

5'X5' DOUBLE LADDER

5'X6'4" TRIPLE LADDER

### SHORING FRAMES

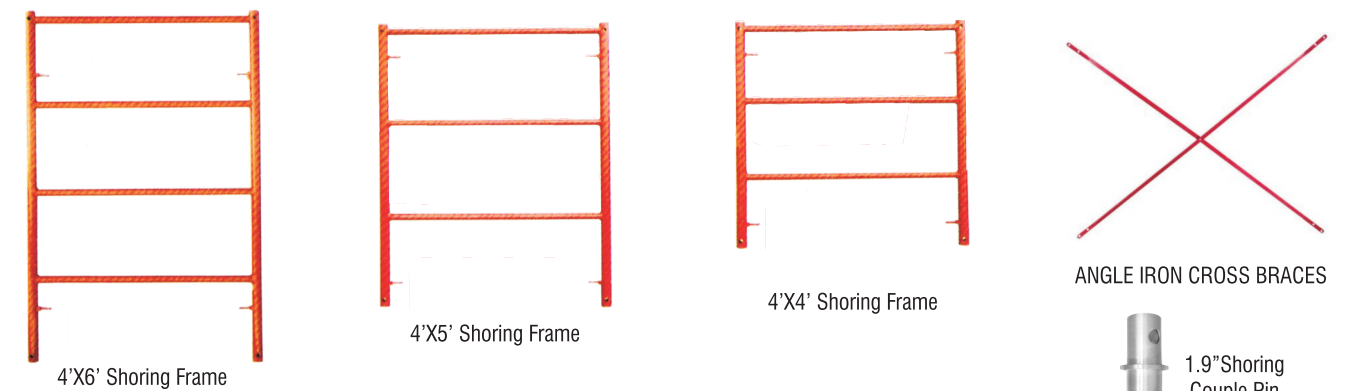

4'X6' Shoring Frame

4'X5' Shoring Frame

4'X4' Shoring Frame

ANGLE IRON CROSS BRACES



### FRAME LOCKS

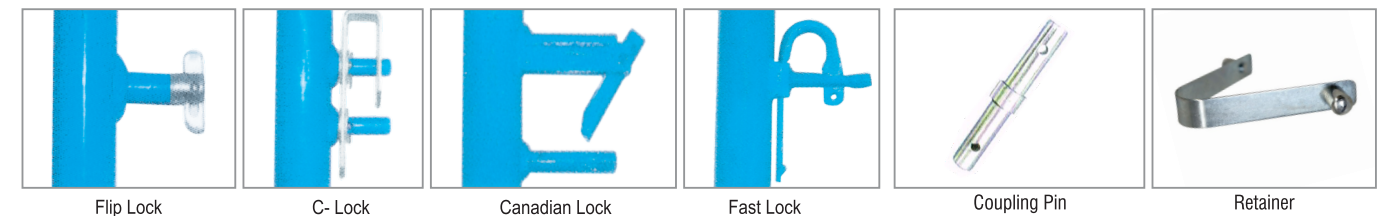

Flip Lock

C- Lock

Canadian Lock

Fast Lock

Coupling Pin

Retainer



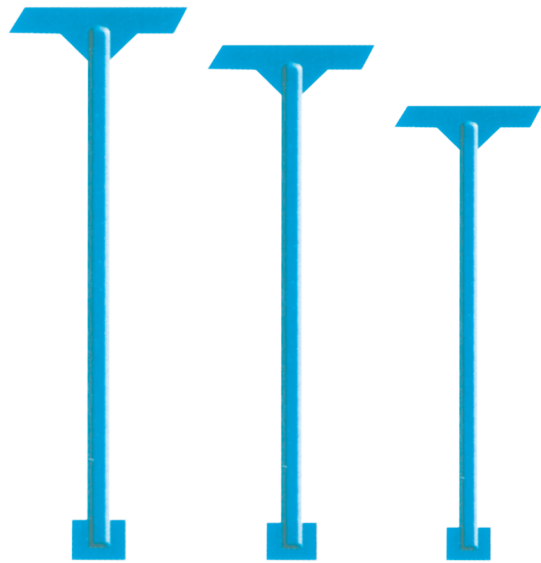

SIDE WALK BRIDGE POLES  
8' TO 20' HEIGHT



MOBILE TOWER



BRACE FOR SIDE WALK BRIDGE 8' & 10' 4"

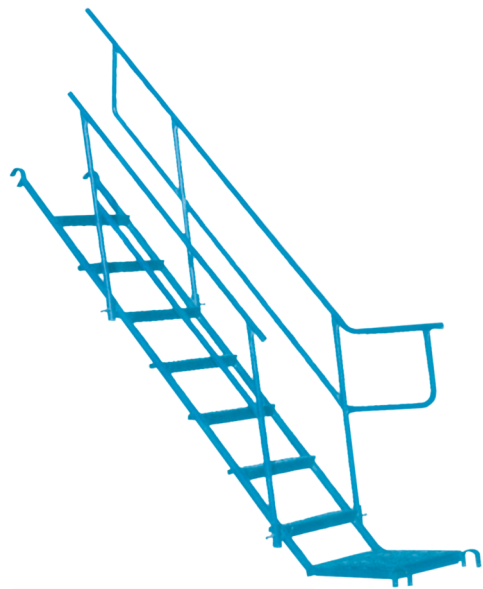

STAIRCASE UNIT WITH HANDRAIL	
Size	
7'X6'	4"
8'X6'	4"
7'X5'	
8'X5'	

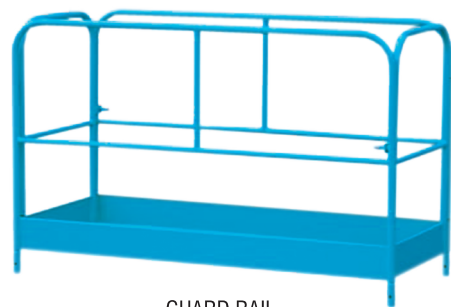

GUARD RAIL

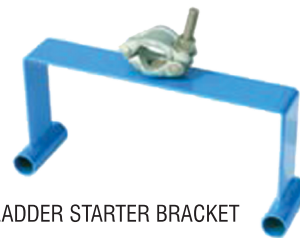

LADDER STARTER BRACKET



LADDER

### ACCESSORIES

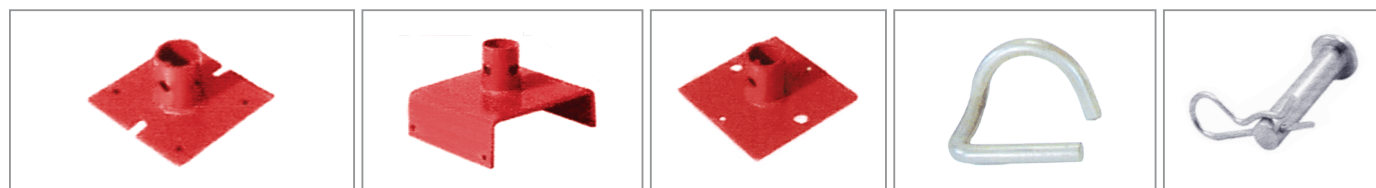

9"x7" Shoring Base Plate

8"x8" Shoring U Head

8"x8" Shoring Base Plate

Gravit Pin-A

Rivet & Hitch Pin

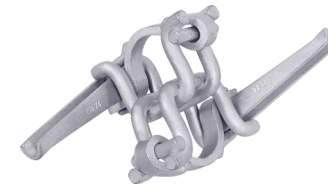

ROD TYPE DOUBLE COUPLER  
FOR TUBE OD 48.3mm



ROD TYPE SWIVEL COUPLER  
FOR TUBE OD 48.3mm



SLEEVE COUPLER / JOINER  
FOR TUBE OD 48.3mm



DOUBLE COUPLER BRITISH TYPE  
FOR TUBE OD 48.3mm  
(EN-74 / BS 1139)



SWIVEL COUPLER BRITISH TYPE  
FOR TUBE OD 48.3mm  
(EN-74 / BS 1139)

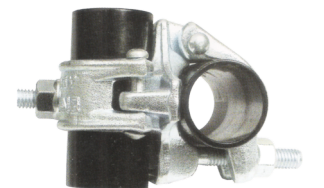

DOUBLE COUPLER GERMAN TYPE  
FOR TUBE OD 48.3mm  
(EN-74 / BS 1139)

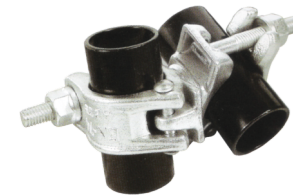

SWIVEL COUPLER GERMAN TYPE  
FOR TUBE OD 48.3mm  
(EN-74 / BS 1139)

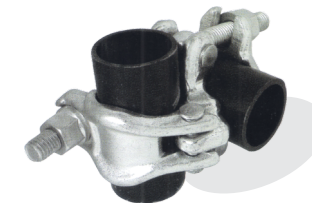

DOUBLE COUPLER USA TYPE  
FOR TUBE OD 48.3mm  
(EN-74 / BS 1139)



SWIVEL COUPLER USA TYPE  
FOR TUBE OD 48.3mm  
(EN-74 / BS 1139)

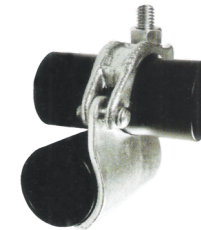

PULL LOG COUPLER  
FOR TUBE OD 48.3mm  
(EN-74 / BS 1139)



FORGED GIRDER COUPLER  
FOR TUBE OD 48.3mm  
(AS - 1576.2)

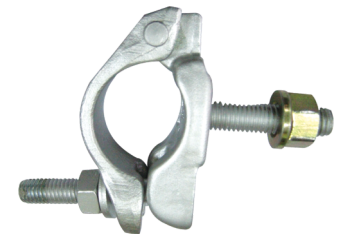

COUPLER WITH WELDED BOLT  
FOR TUBE OD 48.3mm



BOARD RETAINING COUPLER



HALF COUPLER WITH PIN

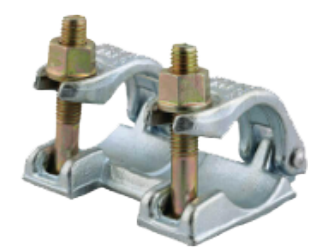

SLEEVE COUPLER (FORGED)



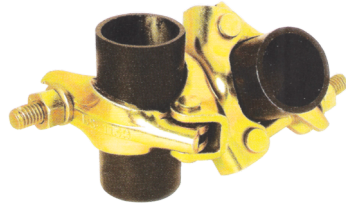

PRESSED SWIVEL COUPLER  
FOR TUBE OD 48.3mm  
(EN-74/BS-1139)

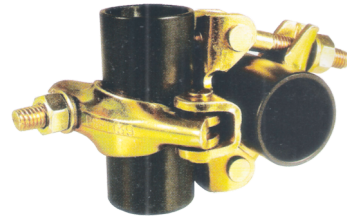

PRESSED DOUBLE COUPLER  
FOR TUBE OD 48.3mm  
(EN-74/BS-1139)

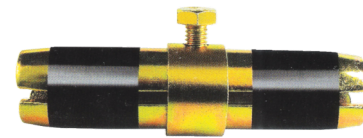

JOINT PIN  
FOR TUBE OD 48.3mm  
(EN-74/BS-1139)

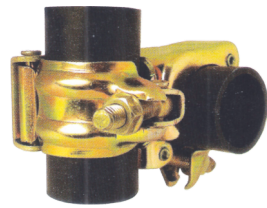

JAPANESE DOUBLE COUPLER  
FOR TUBE OD 48.3MM & 42.3MM  
(JIS : G3444 / SS-311)

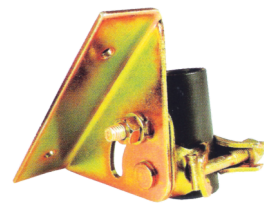

STAIRCASE COUPLER  
FOR TUBE OD 48.3mm  
(BS-1139)

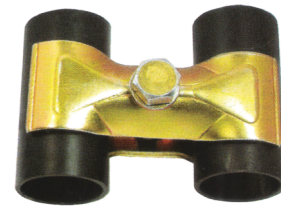

FENCING COUPLER  
FOR TUBE OD 42.3mm / 48.3mm  
(BS-1139)

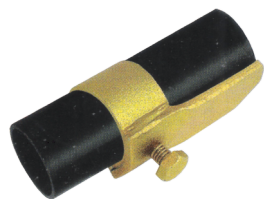

PUTLOG HEAD ADAPTER  
FOR TUBE OD 48.3mm  
(EN-74 / BS-1139)

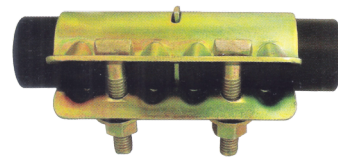

SLEEVE COUPLER  
FOR TUBE OD 48.3mm  
(EN-74 / BS-1139)

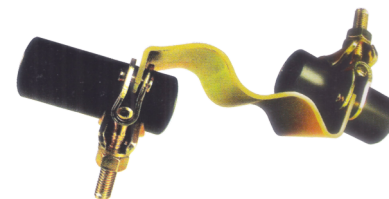

SUPPORT CLAMP  
FOR TUBE OD 48.3mm  
(BS-1139)



JAPANESE SWIVEL COUPLER  
FOR TUBE OD 48.3MM & 42.3MM  
(JIS : G3444 / SS-311)



GRIDER COUPLER  
FOR TUBE OD 48.3mm  
(AS - 1576.2)

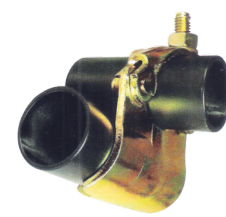

PRESSED PUTLOG COUPLER  
FOR TUBE OD 48.3mm  
(EN-74 / BS-1139)

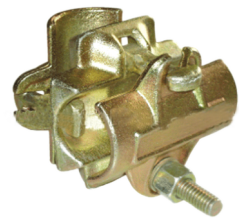

ITALIAN DOUBLE COUPLER  
FOR TUBE OD 48.3mm

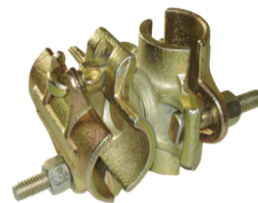

ITALIAN SWIVEL COUPLER  
FOR TUBE OD 48.3mm

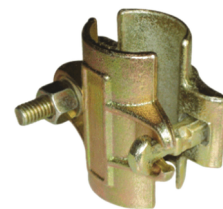

ITALIAN HALF COUPLER  
FOR TUBE OD 48.3mm

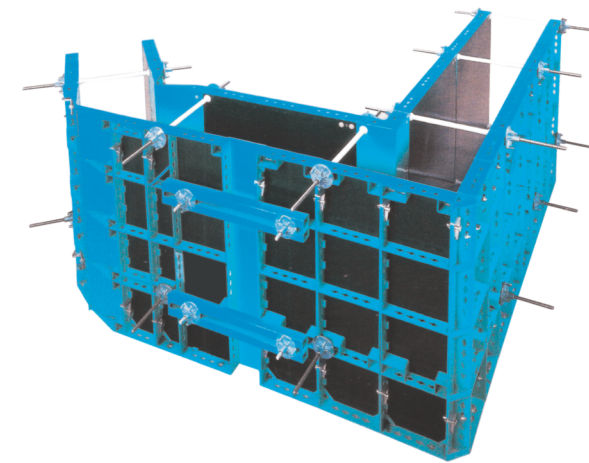

STEEL FORMWORK WITH PLYWOOD



PUSH PULL PROP

Size	Open Height	Closed Height
0	1.83M	1.14M
1	3.12M	1.85M
2	3.35M	2.08M
3	3.96M	2.69M
4	4.88M	3.30M

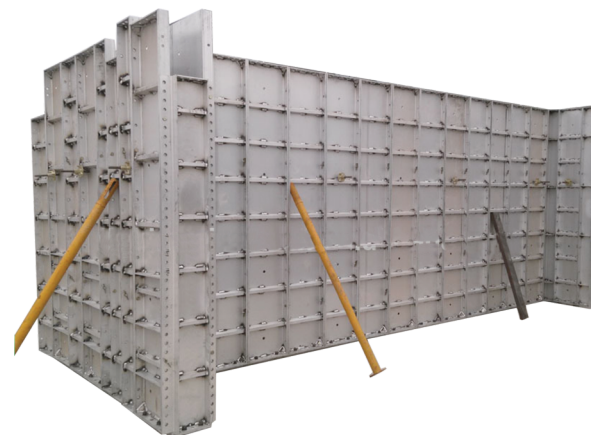

ALUMINIUM FORMWORK PANEL



STEEL FORMWORK



TAPER PIN



WEDGE BOLT



FLAT TIES



FORM BRACE

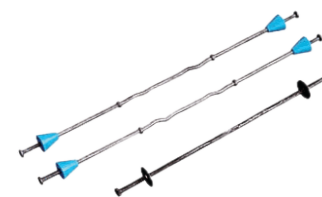

SNAP TIE



FORMWORK WEDGE

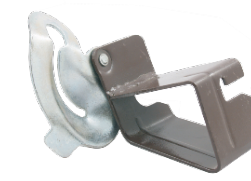

A-BRACKET



WEDGE & BOLT



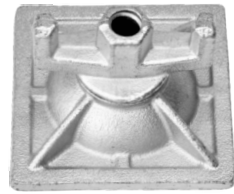

**COMBINATION PLATE SQUARE**  
(PLATE CASTED & NUT FORGED)



**COMBINATION PLATE ROUND**  
(PLATE & NUT FORGED)



**COMBINATION PLATE SQUARE**  
(BODY PRESSED STEEL & NUT CASTED)

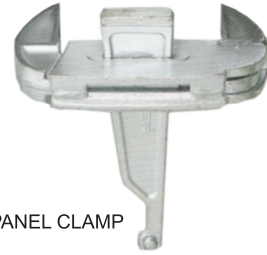

**PANEL CLAMP**

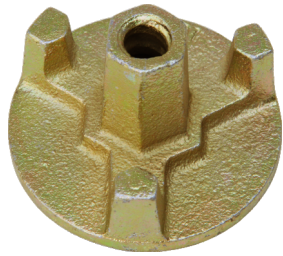

**THREE WING ANCHOR NUT**  
Material : SG Iron  
Size : 100mm  
Weight : 0.640 KG  
Working Load : 90 KN



**TWO WING ANCHOR NUT**  
Material : SG Iron  
Size : Ø 70 / 100mm  
Weight : 0.400/0.590 KG  
Working Load : 90 KN



**THREE WING ANCHOR NUT (70MM)**  
Material : SG Iron  
Size : 70mm  
Weight : 0.460 KG  
Working Load : 90 KN



**TWO WING ANCHOR NUT (70MM)**  
Material : SG Iron  
Size : 70mm  
Weight : 0.440 KG  
Working Load : 90 KN



**FORGED ANCHOR NUT**



**TENSIONER - SCREW TYPE**



**TENSIONER - LEVER TYPE**



**FORGED FIST PLATE**



**WING NUT CASTED**  
Material : SG Iron  
Weight : 0.320 kg.  
Working Load : 90 KN



**FORGED WING NUT**  
Material : EN - 8  
Weight : 0.350 kg.  
Working Load : 90 KN

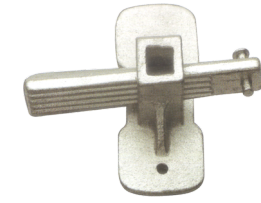

**WEDGE CLAMP**  
Material : High Quality Steel  
(Casted Body & Forged Wedge)  
Size : Ø 4 - 10mm / Ø 7 - 12mm  
Weight : 0.380 Kg / 0.490 Kg

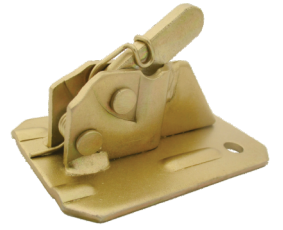

**SPRING CLAMP**  
Material : HR Sheet  
Size : Ø 4 - 10mm  
Weight : 0.460 kg

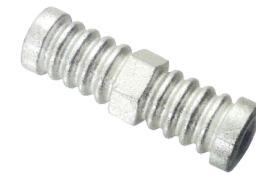

**WATER BARRIER WITHOUT DISC**  
Material : SG Iron  
Size : 120mm Length  
Weight : 0.500 KG



**WATER BARRIER WITH DISC**  
Material : SG Iron  
Size : 116mm Length  
Weight : 0.540 KG



**TIE BAR CONNECTOR**  
Material : Mild Steel  
Size : 100 / 105 mm  
Weight : 0.450 / 0.472 kg.



**HEXAGONAL NUT**  
Material : Mild Steel  
Size : 25 / 30 / 50 / 70 mm  
Weight : 0.105 / 0.126 kg.  
0.210 / 0.294 kg.



COLUMN CLAMP		
Item Code	Adjustment (mtr.)	Wt. (kg.)
7011	0.150-0.510	12.670
7012	0.460-0.815	17.730
7013	0.610-1.220	28.00



**TOE BOARD COUPLER**



**TEKKO CLIP**



**UNIVERSAL CLAMP**



**HOT ROLLED TIE ROD**  
Size : Ø 15mm, upto 6mtr. Length  
Ultimate Load: 190 KN  
Weight : 1.47 KG/Mtr.



**COLD ROLLED TIE ROD**  
Material : EN - 8 / MS  
Size : Ø 15mm, upto 6mtr. Length  
Ultimate Load: 140 / 120 KN  
Weight : 1.47 KG/Mtr.

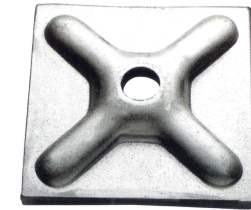

**WALLER PLATE**  
Material : S137  
Size : 120x120x6/10mm  
Weight : 0.660 / 1.10 KG



**STEEL CONE**  
Material : ST 37  
Size : 90mm Length  
Weight : 0.600 KG

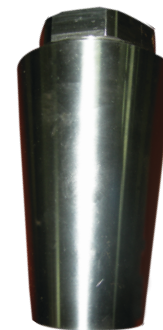

**BIG CONE**  
Material : EN8  
Weight : 3.2 kg.



**BAR COUPLER**

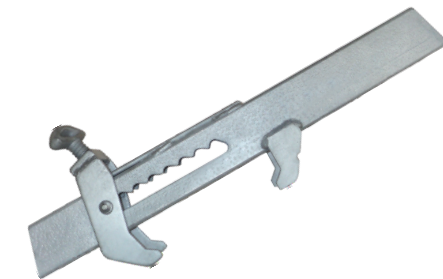

**FORMWORK FLEXIBLE CLAMP**

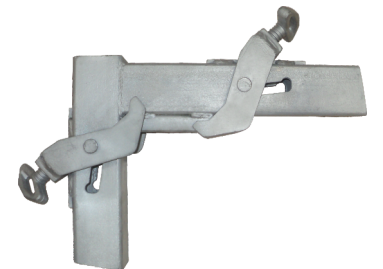

**FORMWORK CORNER CLAMP**





### ADJUSTABLE BASE JACK (TUBE OD 38MM)

Item Code	TL/AL (Mtr)	Wt. (kg.)
6011	0.450/0.350	2.60
6012	0.550/0.450	2.95
6013	0.650/0.550	3.30
6014	0.750/0.650	3.70

### ADJUSTABLE BASE JACK (TUBE OD 34MM)

Item Code	TL/AL (Mtr)	Wt. (kg.)
6021	0.450/0.350	2.45
6022	0.550/0.450	2.75
6023	0.650/0.550	3.10
6024	0.750/0.650	3.40

### ADJUSTABLE BASE JACK (SOLID Ø 32MM)

Item Code	TL/AL (Mtr)	Wt. (kg.)
6031	0.500/0.400	4.60
6032	0.600/0.500	5.35
6033	0.800/0.700	6.70
6034	1.000/0.800	8.12



### UNIVERSAL JACK (TUBE OD 38MM)

Item Code	TL/AL (Mtr)	Wt. (kg.)
6061	0.450/0.350	1.60
6062	0.550/0.450	1.95
6063	0.650/0.550	2.30
6064	0.750/0.650	2.70

### UNIVERSAL JACK (TUBE OD 34mm) (EIJJ-02A)

Item Code	TL/AL (Mtr)	Wt. (kg.)
6071	0.450/0.350	1.45
6072	0.550/0.450	1.75
6073	0.650/0.550	2.10
6074	0.750/0.650	2.40



### ADJUSTABLE U-HEAD (TUBE OD 38mm)

Item Code	TL / AL (mm)	Wt. (kg.)
6051	250 / 100	4.70
6052	300 / 150	5.75
6053	350 / 200	6.80

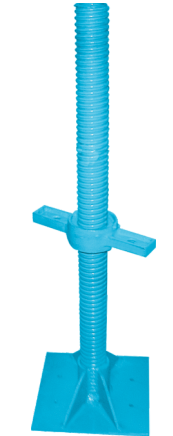

### BASE JACK BLUE PAINTED (TUBE OD 34mm)

Item Code	TL / AL (mm)	Wt. (kg.)
6041	250 / 100	2.40
6042	350 / 200	2.60
6043	500 / 350	3.00
6044	700 / 550	3.60



### ADJUSTABLE SWIVEL JACK (PIPE OD 38MM)

Item Code	TL / AL (mm)	Wt. (kg.)
6081	500/350	3.95
6082	600/450	4.30
6083	800/650	4.95



### ADJUSTABLE FORK HEAD JACK (PIPE OD 38MM)

Item Code	TL / AL (mm)	Wt. (kg.)
6091	500/350	4.35
6092	600/450	4.70
6093	800/650	5.35

### ACCESSORIES

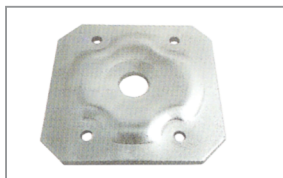

Reinforced Base Plate

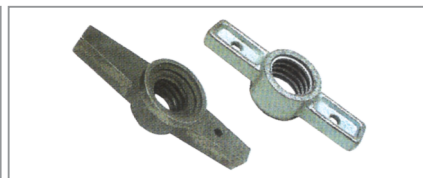

Jack Nut - Casted



Jack Nut - Forged



Base Plate with Pipe



GUARD RAIL WITH 3P



GUARD RAIL 2B + 1P



GUARD RAIL WITH ROD 3P



GUARD RAIL WITH ROD 2B + 1P



GUARD RAIL WITH PIPE 3P



GUARD RAIL WITH PIPE 2B + 1P



ADJUSTABLE GUARD RAIL DUAL PURPOSE



ADJ. GUARD RAIL 1P



ADJ. GUARD RAIL 2B



ADJ. GUARD RAIL 2P



PROTECTIVE BARRIER-1 (Finish:- Hot Dip Galvanization)

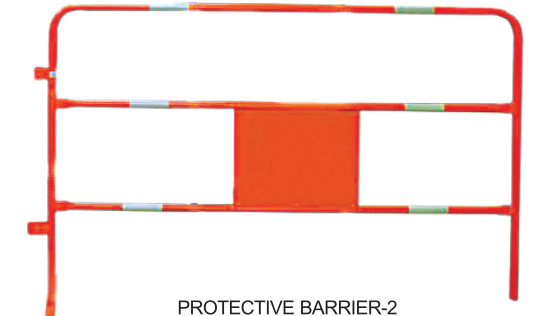

PROTECTIVE BARRIER-2 (Finish:- Powder Coated)





ALUMINIUM MULTI-FUNCTION MOBILE TOWER



ALUMINIUM MULTI-FUNCTION SCAFFOLD TOWER



ALUMINIUM WALK BOARD WITH PLYWOOD

Item Code	Size
8011	19 1/4"x5'
8012	19 1/4"x7'
8013	19 1/4"x8'
8014	19 1/4"x10'



ALUMINIUM PROP.

Item Code	Item Size (mtr)
8061	1.45/2.50
8062	1.95/3.50
8063	2.60/4.80
8064	4.30/6.25



ALUMINIUM LADDER



ALUMINIUM WALK BOARD

Item Code	Size
8021	19 1/4"x5'
8022	19 1/4"x7'
8023	19 1/4"x8'
8024	19 1/4"x10'



ALUMINIUM I-BEAMS

STEEL WALKBOARD		
Item Code	Width/Length (m)	Wt. (kg.)
8031	0.20/1.50	9.23
8032	0.20/2.00	11.62
8033	0.20/2.50	14.20
8034	0.20/3.00	16.74
8035	0.30/1.00	7.10
8036	0.30/2.00	13.58
8037	0.30/2.50	16.70
8038	0.30/3.00	19.90

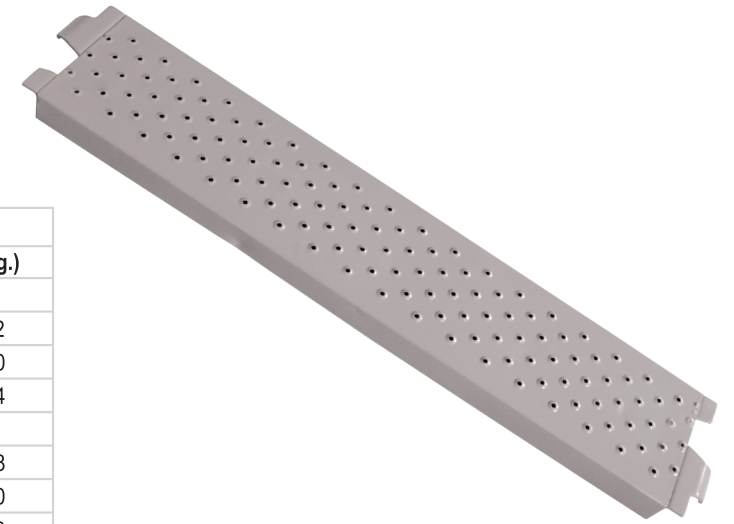

STEEL WALKBOARD		
Item Code	Size	Weight
8051	.50/1.52m	16.30kg
8052	.50/2.13m	22.30kg
8053	.50/3.04m	31.70kg



TRESTLE



DOUBLE ARM TRANSOM (4 BOARD & 5 BOARD)



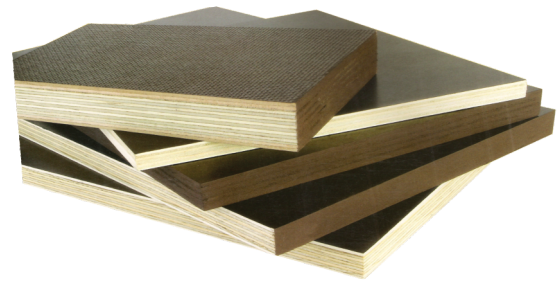

FILM FACED PLYWOOD/BOARD	
Types	Poplar, Birch & Combi
Dimensions	1220x2400, 2500x1250 & 250x625
Thickness (mm)	12, 15, 18, 21 & 30
Glue	WBP & MR
Film	Brown & Black

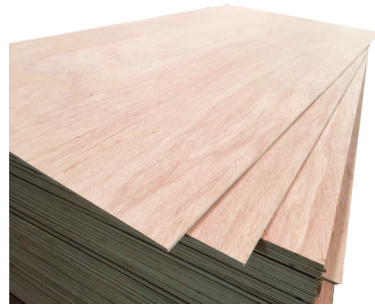

SCAFFOLDING TUBE  
(various diameter and thickness)

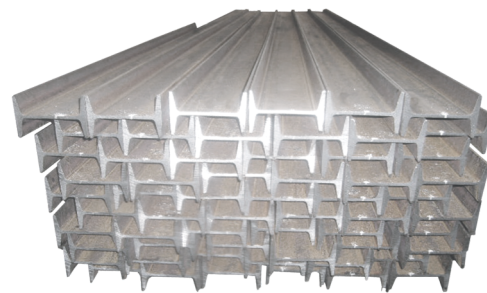

I - BEAM

Dimensions	68X100MM
Thickness(mm)	4.5
	*various size

## CASTER WHEEL & ADJUSTABLE SCAFFOLDING CASTER



EIW- CW01  
5", 6" & 8"



EIW- CW02  
5", 6", 8" & 10"



EIW- CW03  
5", 6", 8" & 10"



EIW- CW04  
6" & 8"

WHEEL DIA	125,150,200 & 250
CAPACITY	220 KG. TO 400 KG
WHEEL	POLYPROPYLENE & CAST IRON

## SAFETY HELMET



SH01



SH02



SH03

## GOGGLES



SG01



SG02



SG03

## GLOVES



SGL01



SGL02



SGL03

## JACKETS



SJ01



SJ02



SJ03

## SHOES



SS01



SS02



SS03

## REFLECTIVE PYRAMIDS



RP01



RP02

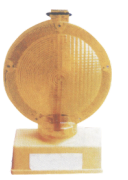

WARNING LIGHT  
WL01